

↗ DOMETIC

MOBILE COOLING

CFF



CFF 45

EN

Compressor Fridge/Freezer

Operating manual

© 2021 Dometic Group. The visual appearance of the contents of this manual is protected by copyright and design law. The underlying technical design and the products contained herein may be protected by design, patent or be patent pending. The trademarks mentioned in this manual belong to Dometic Sweden AB. All rights are reserved.

Please read these instructions carefully and follow all instructions, guidelines, and warnings included in this product manual in order to ensure that you install, use, and maintain the product properly at all times. These instructions **MUST** stay with this product.

By using the product, you hereby confirm that you have read all instructions, guidelines, and warnings carefully and that you understand and agree to abide by the terms and conditions as set forth herein. You agree to use this product only for the intended purpose and application and in accordance with the instructions, guidelines, and warnings as set forth in this product manual as well as in accordance with all applicable laws and regulations. A failure to read and follow the instructions and warnings set forth herein may result in an injury to yourself and others, damage to your product or damage to other property in the vicinity. This product manual, including the instructions, guidelines, and warnings, and related documentation, may be subject to changes and updates. For up-to-date product information, please visit documents.dometic.com, dometic.com.

Contents

1	Explanation of symbols	3
2	Safety instructions	4
3	Scope of delivery	7
4	Intended use	8
5	Function description	8
6	Operation	11
7	Cleaning and maintenance	23
8	Troubleshooting	24
9	Warranty	27
10	Disposal	27
11	Technical data	28

1 Explanation of symbols



WARNING!

Safety instruction: Indicates a hazardous situation that, if not avoided, could result in death or serious injury.



CAUTION!

Safety instruction: Indicates a hazardous situation that, if not avoided, could result in minor or moderate injury.



NOTICE!

Indicates a situation that, if not avoided, can result in property damage.

**NOTE**

Supplementary information for operating the product.

2 Safety instructions



WARNING! Failure to obey these warnings could result in death or serious injury.

Electrocution hazard

- Do not operate the cooling device if it is visibly damaged.
- If this cooling device's power cable is damaged, it must be replaced to prevent safety hazards.
- This cooling device may only be repaired by qualified personnel. Improper repairs can lead to considerable hazards.

Fire hazard

- When positioning the device, ensure the supply cord is not trapped or damaged.
- Do not locate multiple portable socket-outlets or portable power supplies at the rear of the device.

Health hazard

- This device can be used by children aged from 8 years and above and persons with reduced physical, sensory or mental capabilities or lack of experience and knowledge if they have been given supervision or instruction concerning use of the device in a safe way and understand the hazards involved.
- Children shall not play with the device.
- Cleaning and user maintenance shall not be made by children without supervision.
- Children aged from 3 to 8 years are allowed to load and unload cooling devices.

Explosion hazard

- Do not store any explosive substances such as spray cans with a flammable propellant in the cooling device.



CAUTION! Failure to obey these cautions could result in minor or moderate injury.

Electrocution hazard

- Before starting the cooling device, ensure that the power supply line and the plug are dry.
- Disconnect the cooling device from the power supply
 - before each cleaning and maintenance
 - after every use

Health hazard

To avoid contamination of food, please respect the following instructions:

- Please check if the cooling capacity of the device is suitable for storing the food or medicine you wish to cool.
- Food may only be stored in its original packaging or in suitable containers.
- Opening the cooling device for long periods can cause significant increase of the temperature in the compartments of the device.
- Clean regularly surfaces that can come in contact with food and accessible drainage systems.
- If the device is left empty for long periods:
 - Switch off the device.
 - Defrost the device.
 - Clean and dry the device.
 - Leave the lid open to prevent mould developing within the device.



NOTICE! Damage hazard

- Check that the voltage specification on the type plate corresponds to that of the energy supply.
- Only connect the cooling device as follows:
 - With the DC connection cable to a DC power supply in the vehicle
 - Or with the AC connection cable to an AC power supply
- Never pull the plug out of the socket by the cable.
- If the cooling device is connected to a DC outlet: Disconnect the cooling device and other power consuming devices from the battery before connecting a quick charging device.
- If the cooling device is connected to a DC outlet: Disconnect the cooling device or switch it off when you turn off the engine. Otherwise you may discharge the battery.

- The cooling device is not suitable for transporting caustic materials or materials containing solvents.
- The insulation of the cooling device contains flammable cyclopentane and requires special disposal procedures. Deliver the cooling device at the end of its life-cycle to an appropriate recycling center.
- Do not use electrical devices inside the cooling device unless they are recommended by the manufacturer for the purpose.
- Do not place the cooling device near naked flames or other heat sources (heaters, direct sunlight, gas ovens etc.).
- **Risk of overheating!**
Ensure at all times that there is a minimum of 50 mm ventilation on all four sides of the cooling device. Keep the ventilation area free of any objects that could restrict the air flow to the cooling components. Do not place the cooling device in closed compartments or areas with none or minimal air flow.
- Ensure that the ventilation openings are not covered.
- Do not fill the inner container with ice or fluids.
- Never immerse the cooling device in water.
- Protect the cooling device and cables against heat and moisture.
- The device shall not to be exposed to rain.

3 Scope of delivery

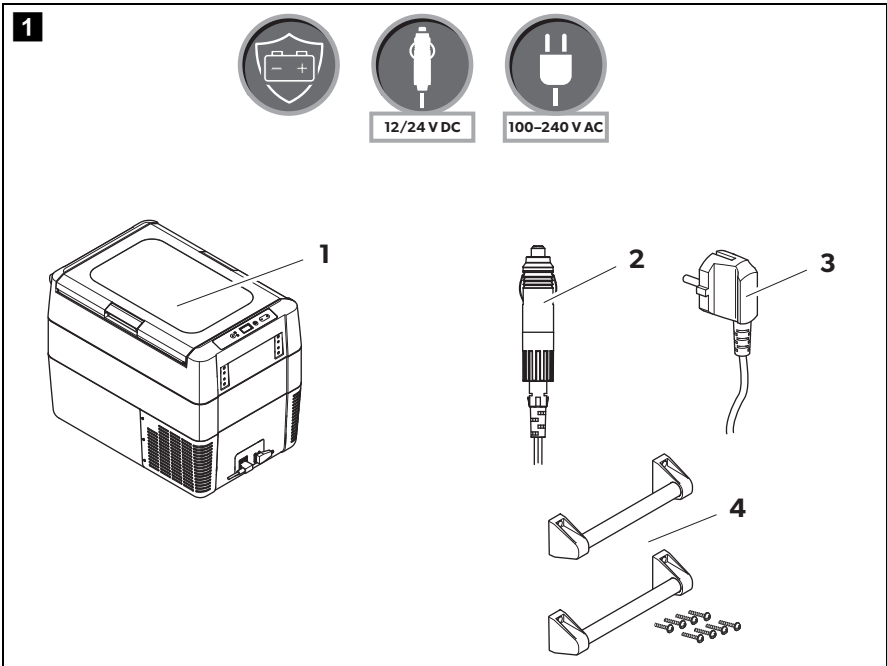

Item	Quantity	Description
1	1	Cooler
2	1	Connection cable for DC connection
3	1	Connection cable for AC connection
4	2	Carry handle, consisting of: <ul style="list-style-type: none"> • 2 holders • 1 handle • 4 fastening screws • 1 allen wrench
-	1	Operating manual

4 Intended use

The cooling device is suitable for cooling food. The cooling device is suitable for use in vehicles or on boats.

The cooling device is designed to be operated from a DC on-board power supply of a vehicle or boat, a DC auxiliary battery or from an AC power supply.

The cooling device is suitable for camping use.

The cooling device is intended to be used in household and similar applications such as

- staff kitchen areas in shops, offices and other working environments
- farm houses
- clients in hotels, motels and other residential type environments
- bed and breakfast type environments
- catering and similar non-retail applications

This product is only suitable for the intended purpose and application in accordance with this instruction. Any other use, deviating from the intended use, is not allowed! Dometic accepts no liability for any loss, damage or injury incurred, directly or indirectly due to other than the intended use.

5 Function description

The cooler can chill products, keep them cool as well as freeze them. A low maintenance refrigerant circuit with compressor provides the cooling. The generous insulation and powerful compressor ensure efficient and fast cooling.

The cooler is portable.

The cooler can withstand a short-term inclination of 30°, for example on boats.

5.1 Scope of functions

- Power supply with priority circuit for connecting to the AC mains
- Three-level battery monitor to protect the vehicle battery switches off automatically at low battery voltage
- Display with temperature gauge in °C and °F
- Temperature setting: With two buttons in steps of 1 °C (2 °F)
- Display dimming function with 3 brightness levels
- Removable wire basket
- Removable carrying handles

5.2 Operating and display elements

Lid latches

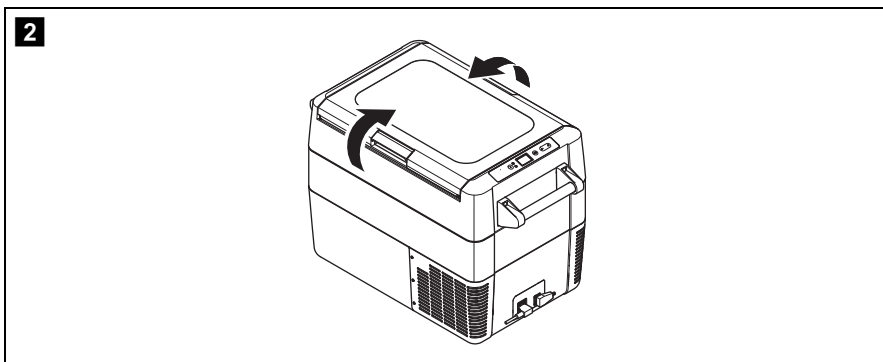

Operating panel

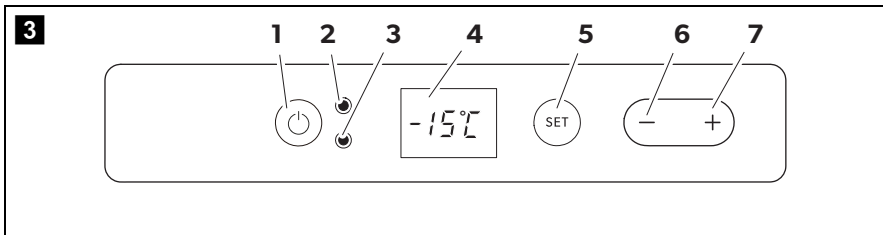

Item	Description	Explanation
1	ON OFF	Switches the cooler on or off when the button is pressed for between one and two seconds

Item	Description	Explanation	
2	POWER "⏻"	Status indication	
		LED lights up green:	Compressor is on
		LED lights up orange:	Compressor is off
		LED flashes orange:	Display switched off automatically due to low battery voltage
3	ERROR	LED flashes red: Device is switched on but not ready for operation	
4	-	Display, shows the information	
5	SET	Selects the input mode - Temperature setting - Celsius or Fahrenheit display - Set battery monitor - Set brightness of display	
6	DOWN -	Press once to decrease the value	
7	UP +	Press once to increase the value	

Connection sockets

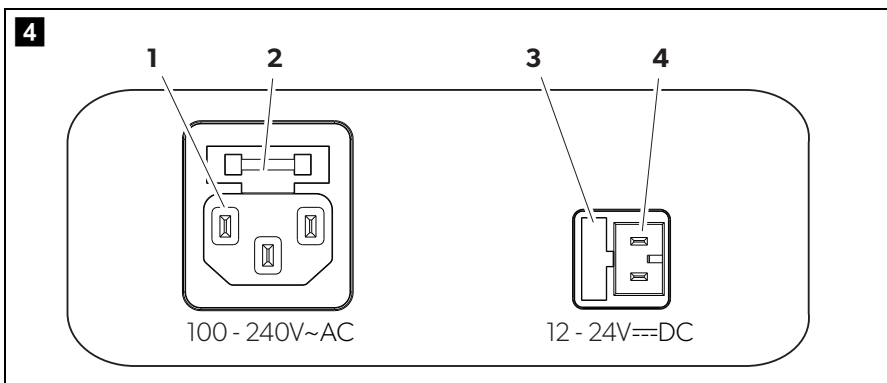

Item	Description
1	Connection socket AC voltage supply
2	AC fuse holder
3	DC fuse cover
4	Connection socket DC voltage supply

6 Operation

6.1 Before initial use

**NOTE**

Before starting your new cooler for the first time, you should clean it inside and outside with a damp cloth for hygienic reasons (please also refer to the chapter "Cleaning and maintenance" on page 23).

Mounting the handles

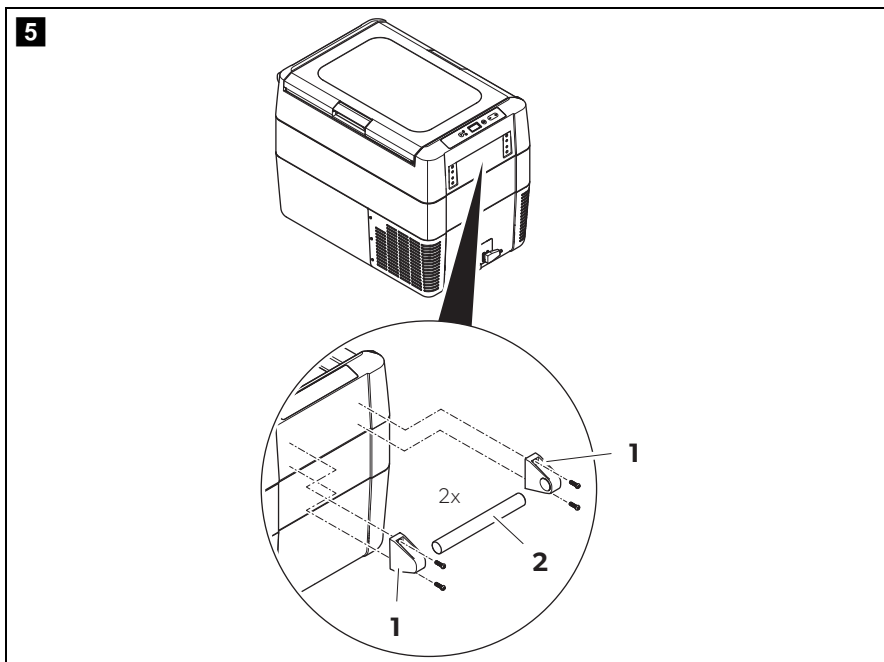

The handles are enclosed unassembled. If you wish to attach the handles, proceed as follows:

- ▶ Assemble a handle by putting two holders (**1**) and a handle (**2**) together.
- ▶ Fasten the holders with the enclosed screws in the holes provided.

Opening or removing the lid

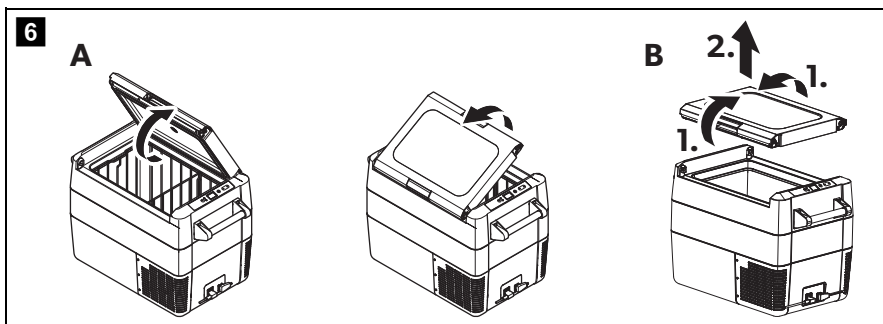

- ▶ To open the lid, unlatch (A).
The lid can be opened from either side.
- ▶ To remove the lid, unlatch both sides at the same time (B)

Lid stop position

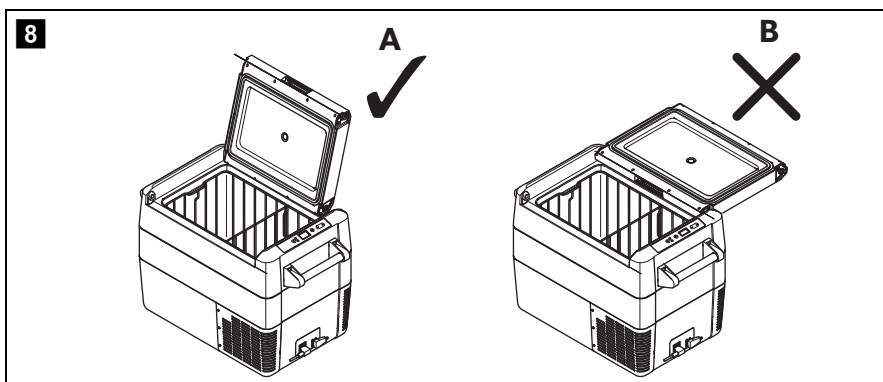

The lid has a built-in stop position (A). Do not force the lid past the built-in stop (B).



NOTICE! DAMAGE HAZARD

If the lid has been forced too far, follow the steps described in the chapter "The lid has been forced past the built-in stop" on page 26.

Removing the basket



NOTICE! DAMAGE HAZARD!

Removing the basket with the lid open may scratch the lid and deform the basket. We recommend to remove the lid (fig. **6**) before removing the basket (fig. **9**).

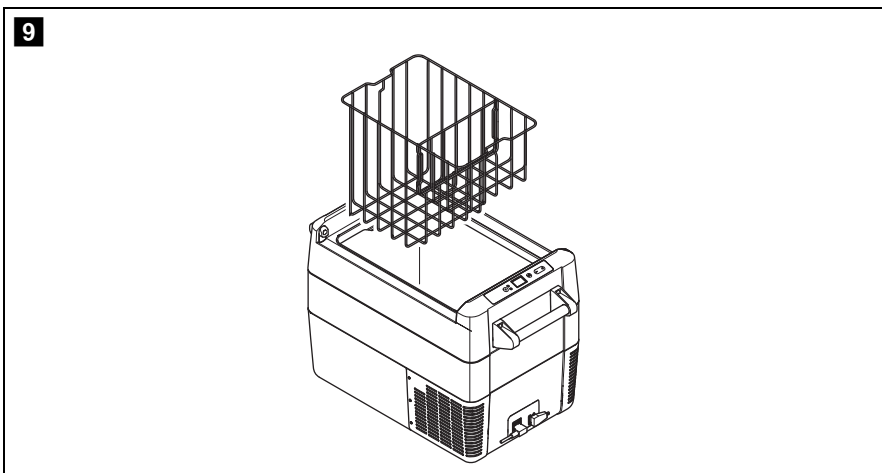

Selecting the temperature units

Temperature display units can be switched between Celsius and Fahrenheit as follows:

- Switch on the cooler.
- Press the "SET" button twice (fig. **3** 5, page 9).
- Use the "UP +" (fig. **3** 7, page 9) or "DOWN -" (fig. **3** 6, page 9) buttons to select Celsius or Fahrenheit.
- ✓ The selected temperature unit then appears in the display for a few seconds. The display flashes several times before it returns to the current temperature.

6.2 Saving energy

- Choose a well ventilated location which is protected from direct sunlight.
- Allow warm food to cool down first before placing it in the cooling device to keep cool.
- Do not open the cooling device more often than necessary.

- Do not leave the cooling device open for longer than necessary.
- If the cooler has a basket: For optimal energy consumption, position the basket according to its position on delivery.
- On a regularly basis, make sure the lid seal still fits properly.
- Defrost the cooler once a layer of ice forms.
- Avoid unnecessarily low temperatures.

6.3 Connecting the cooler

Connecting to a battery (Vehicle or boat)

The cooler can be operated with 12 V or 24 V $\overline{=}$.



NOTICE! DAMAGE HAZARD

Disconnect the cooler and other consumer units from the battery before you connect the battery to a quick charging device. Overvoltage can damage the electronics of the device.

For safety reasons the cooler is equipped with an electronic system to prevent polarity reversal. This protects the cooler against short-circuiting when connecting to a battery.

Using the fused DC plug



NOTICE! DAMAGE HAZARD

For protection of the device the DC cable supplied includes a fuse inside the plug. Do **not** remove the fused DC plug. Only use the DC cable supplied.

- Plug the DC connection cable (fig. **1** 2, page 7) into the DC voltage socket of the cooler (fig. **4** 3, page 10).
- Connect the connection cable to a DC power outlet.

Connecting to an AC power supply (e.g. in the home or office)



DANGER! ELECTROCUTION HAZARD

Failure to obey these warnings will result in death or serious injury.

- Never handle plugs and switches with wet hands or if you are standing on a wet surface.
- If you are operating your cooler on board a boat from a AC power supply, you must install a residual current circuit breaker between the AC power supply and the cooler.
Seek advice from a trained technician.

The coolers have an integrated multi-voltage power supply with priority circuit for connecting to an AC voltage source. The priority circuit automatically switches the cooler to AC operation if the device is connected to an AC power supply, even if the DC connection cable is still attached.

When switching between the AC power supply and the battery supply, the red LED may light up briefly.

- Plug the AC connection cable (fig. **1** 3, page 7) into the AC voltage socket of the cooler (fig. **4** 1, page 10).
- Connect the connection cable to an AC power outlet.

6.4 Using the battery monitor

The device is equipped with a multi-level battery monitor that protects your vehicle battery against excessive discharging when the device is connected to the on-board DC supply.

If the cooler is operated when the vehicle ignition is switched off, the cooler switches off automatically as soon as the supply voltage falls below a set level. The cooler will switch back on once the battery has been recharged to the restart voltage level.



NOTICE! DAMAGE HAZARD

When switched off by the battery monitor, the battery will no longer be fully charged. Avoid starting repeatedly or operating current consumers without longer charging phases. Ensure that the battery is recharged.

In "HIGH" mode, the battery monitor responds faster than at the levels "LOW" and "MED" (see the following table).

Battery monitor mode	LOW	MED	HIGH
Switch-off voltage at 12 V	10.1 V	11.2 V	11.8 V
Restart-voltage at 12 V	11.4 V	12.2 V	12.6 V
Switch-off voltage at 24 V	21.5 V	24.1 V	24.6 V
Restart voltage at 24 V	23.0 V	25.3 V	26.2 V

The battery monitor mode can be selected as follows:

- ▶ Switch on the cooler.
- ▶ Press the "SET" button three times (fig. **3** 5, page 9).
- ▶ Use the "UP +" (fig. **3** 7, page 9) or "DOWN -" (fig. **3** 6, page 9) buttons to select the battery monitor mode.
- ✓ Display will be as follows:
Lo (LOW), ΠEd (MED), Hi (HIGH)
- ✓ The selected mode then appears in the display for a few seconds. The display flashes several times before it returns to the current temperature.



NOTE

When the cooler is supplied by the starter battery, select the battery monitor mode "HIGH". If the cooler is connected to a supply battery, the battery monitor mode "LOW" will suffice.

6.5 Using the cooler



NOTICE! OVERHEATING HAZARD

Ensure at all times that there is sufficient ventilation so that the heat that generated during operation can dissipate. Ensure that the ventilation slots are not covered. Make sure that the device is sufficiently far away from walls and other objects so that the air can circulate.

- ▶ Place the cooler on a firm foundation.
Make sure that the ventilation slots are not covered and that the heated air can dissipate. We recommend keeping a gap of at least 50 mm around ventilation holes.



NOTE

Place the cooler as shown (fig. **1**, page 7). If you operate the cooler in a different orientation it can be damaged.

- ▶ Connect the cooler (see chapter “Connecting the cooler” on page 14).



NOTICE! EXCESSIVELY LOW TEMPERATURE HAZARD

Ensure that the only those objects are placed in the cooler that are intended to be cooled at the selected temperature.

- ▶ Press the “ON/OFF” button (fig. **3** 1, page 9) for between one and two seconds.
- ✓ The LED “⏻” lights up (fig. **3** 2, page 9).
- ✓ The display (fig. **3** 4, page 9) switches on and shows the current temperature.
- ✓ The cooler starts cooling the interior.



NOTE

When operating from a battery, the display switches off automatically if the battery voltage is low. The LED “⏻” flashes orange.

Latching the cooler lid

- ▶ Close the lid.
- ▶ Press the latch (fig. **2**, page 9) down, until it latches in place audibly.



NOTE

When latching the lid, ensure that both latch side pins are fully engaged to ensure a good lid seal. One latch may engage slightly before the other.

If the lid is not closed equally at both sides, press until a second click is heard.

6.6 Setting the temperature

- ▶ Press the "SET" button once (fig. **3** 5, page 9).
- ▶ Use the "UP +" (fig. **3** 7, page 9) and "DOWN -" (fig. **3** 6, page 9) buttons to select the cooling temperature.
- ✓ The cooling temperature appears in the display for a few seconds. The display flashes several times and then the current temperature is displayed again.

6.7 Setting the display brightness

The display brightness can be dimmed for low ambient light conditions. To set the dimming level of the display proceed as follows:

- ▶ Switch on the cooler.
- ▶ Press the "SET" button four times (fig. **3** 5, page 9).
- ▶ Use the "UP +" (fig. **3** 7, page 9) or "DOWN -" (fig. **3** 6, page 9) buttons to set the brightness of the display.
- ✓ Display will be as follows:
d0 (default), d1 (medium), d2 (dark)
- ✓ The display shows the set mode for several seconds. The display flashes twice before it returns to the current temperature.



NOTE

- The factory setting of brightness of the display is d0 (default).
- If a fault occurs, the brightness automatically reverts to brightness d0 (default). After troubleshooting the set brightness is reactivated.

6.8 Switching off the cooler

- ▶ Empty the cooler.
- ▶ Switch the cooler off.
- ▶ Pull out the connection cable.

If you do not want to use the cooler for a longer period of time:

- ▶ Leave the lid slightly open. This prevents odor build-up.

6.9 Defrosting the cooler

Humidity can form frost in the interior of the cooling device or on the evaporator. This reduces the cooling capacity.



NOTICE! DAMAGE HAZARD

Never use hard or pointed tools to remove ice or to loosen objects which have frozen in place.

To defrost the cooler, proceed as follows:

- Take out the contents of the cooler.
- If necessary, place them in another cooling device to keep them cool.
- Switch off the device.
- Leave the lid open.
- Wipe off the defrosted water.

6.10 Replacing the AC fuse



DANGER! ELECTROCUTION HAZARD

Failure to obey this warning will result in death or serious injury. Disconnect the power supply and the connection cable before you replace the device fuse.

- Disconnect the power supply to the device.
- Remove the connection cable.
- Pry out the fuse insert (fig. **4** 2, page 10) with a screwdriver.
- Replace the defective glass fuse with a new one that has the same type and rating (4 A, 250 V).
- Press the fuse insert back into the housing.
- Reconnect the power supply to the device.

6.11 Replacing the device DC Fuse

- ▶ Disconnect the power supply to the device.
- ▶ Pry out the fuse cover (fig. **4** 3, page 10) to access the fuse.
- ▶ Reverse the fuse cover and use the hook to remove the fuse.
- ▶ Replace the defective fuse with a new fuse of the same type (Automotive Standard blade fuse, 10 A).
- ▶ Re-fit the fuse cover.
- ▶ Reconnect the power supply to the device.

6.12 Replacing the DC plug fuse

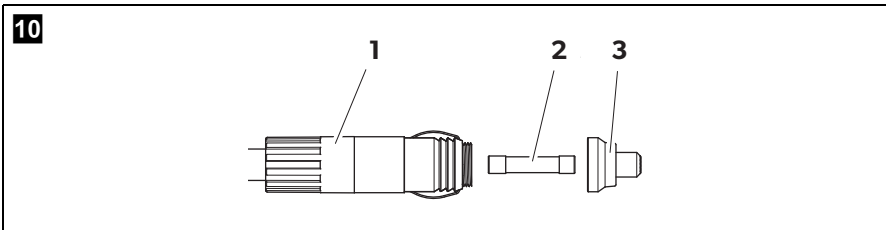

- ▶ Unscrew the contact pin housing (**3**) from the plug (**1**).
- ▶ Replace the defective fuse (**2**) with a new fuse of the same type and rating (3AG, Fast Acting, 10 A).
- ▶ Re-assemble the plug in reverse order.

6.13 Replacing the light PCB

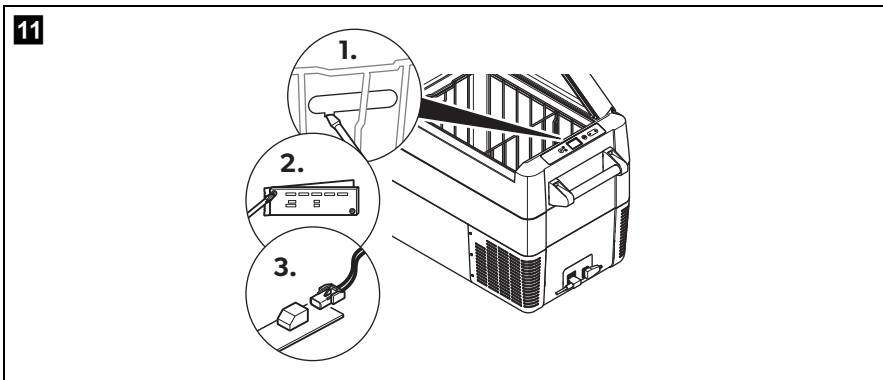

- Disconnect the power supply to the device.
- Pry out the transparent cover with a screwdriver (1).
- Unscrew the PCB mounting screws (2).
- Pull out the plug from the PCB (3).
- Replace the defective light PCB with a new one.
- Fit new PCB using reverse of removal instructions.
- Press the transparent cover back into the housing.
- Reconnect the power supply to the device.

7 Cleaning and maintenance



WARNING! ELECTROCUTION HAZARD

Failure to obey this warning could result in death or serious injury. Always disconnect the device from the power supply before you clean and service it.



NOTICE! Damage hazard

- Never clean the cooler under running water or in dish water.
- Do not use abrasive cleaning agents or hard objects during cleaning as these can damage the cooler.

- Occasionally clean the device interior and exterior with a damp cloth.
- Make sure that the air inlet and outlet vents on the device are free of any dust and dirt, so that heat can be released and the device is not damaged.

8 Troubleshooting

Fault	Possible cause	Suggested remedy
Device does not function, LED does not glow.	No voltage present in the connected power outlet.	Plugged in DC power outlet: In most vehicles the ignition must be turned on before power will be supplied to the DC power outlet. Plugged in AC power outlet: Try using another plug outlet.
	One of the device fuses is defective.	Replace the defective device fuse, see chapter "Replacing the AC fuse" on page 20 or chapter "Replacing the device DC Fuse" on page 21.
	The integrated mains adapter is defective.	This can only be repaired by an authorised repair center.
The device does not cool (plug is inserted, "POWER" LED is lit).	Defective compressor.	This can only be repaired by an authorised repair center.
The device does not cool (plug is inserted, "POWER" LED flashes orange, display is switched off).	Battery monitor is set too high.	Select a lower battery monitor setting.
	Battery voltage is too low.	Test the battery and charge it as needed.

Fault	Possible cause	Suggested remedy
<p>When operating from the DC outlet: The ignition is on and the device is not working and the LED is not lit.</p>	<p>The DC outlet is dirty. This results in a poor electrical contact.</p>	<p>If the plug of your cooler becomes very warm in the DC outlet, either the DC outlet must be cleaned or the plug has not been assembled correctly.</p>
	<p>The fuse of the DC plug has blown.</p>	<p>Replace the fuse in the DC plug, see chapter "Replacing the DC plug fuse" on page 21.</p>
	<p>The device DC fuse has blown.</p>	<p>Replace the defective fuse, see chapter "Replacing the device DC Fuse" on page 21.</p>
	<p>The vehicle fuse has blown.</p>	<p>Replace the vehicle's DC outlet fuse. Please refer to your vehicle's operating manual.</p>
<p>The display shows an error message (e.g. "Err1") and the appliance does not cool.</p>	<p>The appliance has switched off due to an internal fault.</p>	<p>This can only be repaired by an authorised repair center.</p>

8.1 The lid has been forced past the built-in stop

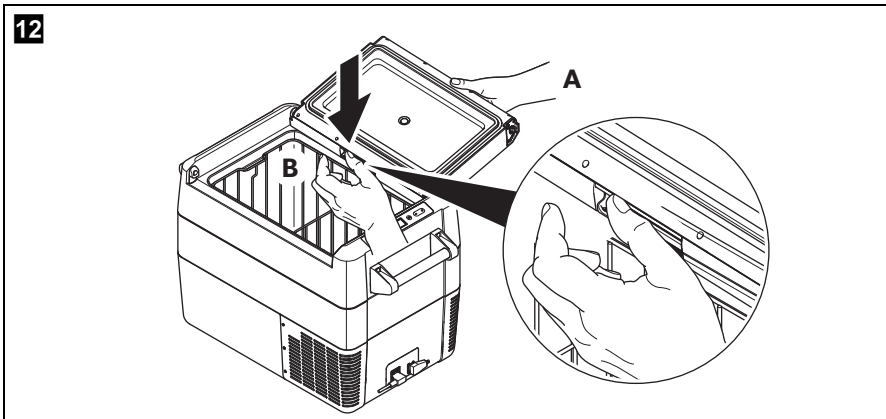

- Support the lid with one hand (A).
- Hold the latch down with the other hand (B).



CAUTION! HEALTH HAZARD

Failure to obey this caution could result in minor or moderate injury. Beware pinching your thumb while closing the lid.



NOTICE! DAMAGE HAZARD!

Failure to observe this instruction can cause the lid to break off.

- Close the lid as far as possible without pinching your thumb, while still holding the latch down, to keep it from breaking.
- ✓ The lid should now be approximately at the angle shown (fig. 12).
- Remove the hand from the latch (B), and continue closing the lid all the way.



NOTE

The hinges may release from the correct position during the final closing action. Reposition the lid as follows:

- Operate the latches on both sides of the lid simultaneously.
- Lift and reposition the lid.

**NOTICE! Damage hazard**

- Never clean the cooler under running water or in dish water.
- Do not use abrasive cleaning agents or hard objects during cleaning as these can damage the cooler.

- Occasionally clean the device interior and exterior with a damp cloth.
- Make sure that the air inlet and outlet vents on the device are free of any dust and dirt, so that heat can be released and the device is not damaged.

9 Warranty

Comprehensive warranty details for this product are included in the separate Warranty Certificate. For service or warranty assistance, please contact the manufacturer via details on the back of this operating manual.

For warranty and repair processing, please have the following information available:

- A copy of the proof of purchase
- A reason for the claim or description of the fault

10 Disposal

- Place the packaging material in the appropriate recycling waste bins, wherever possible.



If you wish to finally dispose of the product, ask your local recycling center or specialist dealer for details about how to do this in accordance with the applicable disposal regulations.

11 Technical data

	CFF45
Connection voltage:	12/24 V=== 100 to 240 V~
Rated current:	12 V===: 8.6 A 24 V===: 3.8 A 240 V~: 0.41 A
Cooling capacity:	+10 °C to -18 °C (+50 °F to 0 °F)
Total volume:	44 l
Climate class:	N, T
Ambient temperature:	+16 °C to +43 °C +60 °F to +110 °F
Refrigerant:	R134a
Refrigerant volume:	43 g
CO ₂ equivalent:	0.061 t
Global warming potential (GWP):	1430
Dimensions (W x H x D) in mm (including handles):	715 x 475 x 398
(W x H x D) in mm (with handles removed):	590 x 475 x 398
Weight:	18.9 kg



NOTE

If the ambient temperature is above +32 °C (+90 °F), the minimum temperature cannot be attained.

Test/certificates:



This product contains fluorinated greenhouse gases.

The cooling unit is hermetically sealed.

DOMETIC Australia
PO Box 2495
Burleigh BC QLD 4220

Ph: 1800 21 21 21 (Mon-Fri 8:00am to 5:00pm AEST)
Email: qldservice@dometic.com.au

